

University of Toronto

Final Exam

Date - Dec 11, 2015

Duration: 2.5 hrs

ECE331 — Analog Electronics

Lecturer - D. Johns

ANSWER QUESTIONS ON THESE SHEETS USING BACKS IF NECESSARY

1. Equation sheet is on last page of test.
 2. Unless otherwise stated, use transistor parameters on equation sheet and assume $g_m r_o \gg 1$.
 3. Non-programmable calculator allowed; No other aids allowed
 4. Grading indicated by []. Attempt all questions since a blank answer will certainly get 0.
-

Last Name: _____

First Name: _____

Student #: _____

Question	Mark
1	
2	
3	
4	
5	
6	
Total	

(max grade = 36)

[6] **Question 1:** Consider the wide swing current mirror below where the desired output current is $20\mu\text{A}$. Given that M_1 and M_2 are identical in size and the minimum output voltage is 0.4V , find the length of the transistors such that the current mirror output resistance is $72\text{M}\Omega$

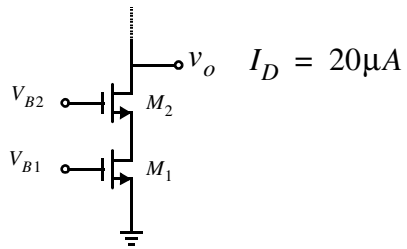

$$L =$$

[6] **Question 2:** Consider the multistage amplifier shown below. All current sources and transistors have the same output impedance of $r_o = 25\text{k}$. Also all transistors have $g_m = 1\text{mA/V}$. Find the gains, v_1/v_i , v_2/v_1 , and v_3/v_2 .

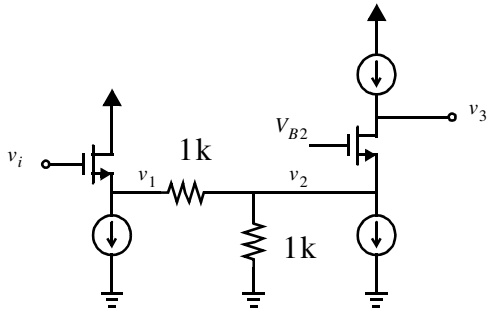

$v_1/v_i =$
$v_2/v_1 =$
$v_3/v_2 =$

[6] Question 3: Consider the transistor below where it is biased such that $V_{ov} = 0.3V$. Including the effects of C_{gs} and C_{gd} , find the frequency, f_{45} , where the impedance has a phase angle of -45° (in Hz). Ignore r_o .

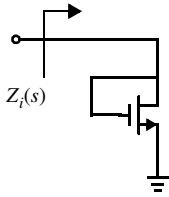

$$\begin{aligned}
 V_{ov} &= 0.3V \\
 W &= 4\mu m \\
 L &= 0.3\mu m \\
 r_o &\rightarrow \infty
 \end{aligned}$$

$f_{45} =$

[6] Question 4: Consider the circuit shown below.

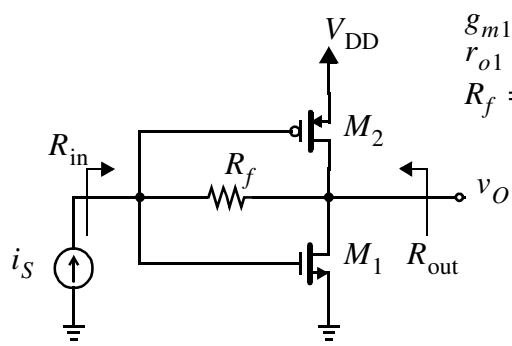

$$g_{m1} = g_{m2} = 100 \mu\text{A/V}$$

$$r_{o1} = r_{o2} = 50\text{k}$$

$$R_f = 25\text{k}$$

$$A_{cl} \equiv v_O / i_S$$

Hint: transconductance g_{m1} is parallel to g_{m2}

a) Find L , A_∞ and d .

$L =$
$A_\infty =$
$d =$

b) Find v_o/i_s , R_{in} and R_{out} .

$v_o/i_s =$
$R_{in} =$
$R_{out} =$

[6] Question 5:

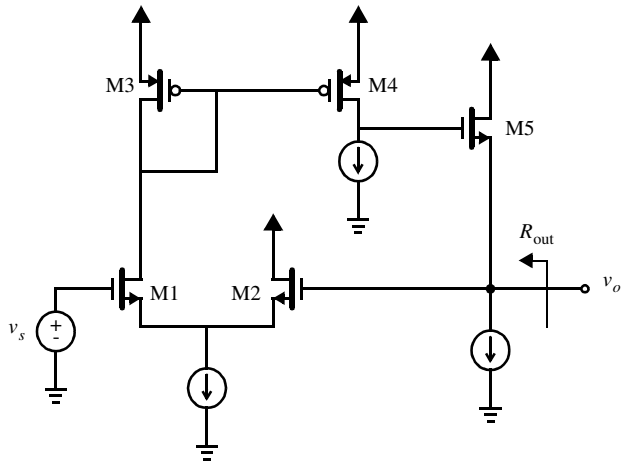

All transistor $g_m = 500\mu\text{A/V}$
 All transistor $r_o = 50\text{k}$
 All current sources ideal

$v_o/v_s =$
$R_{out} =$

Using feedback analysis find v_o/v_s and R_{out} (hint: $d = 0$)

[6] Question 6: Consider an opamp having an open-loop voltage gain of 80 dB and poles at 10^5 , 2×10^6 and 10^8 Hz. It should be compensated to have approx 45 degree PM for closed-loop gains as low as 0 dB.

a) If the pole at 10^5 Hz is moved to a lower frequency (and all other poles remain unaffected), find the frequency at which the dominant pole should be placed (in Hz).

$$f_{p1} =$$

b) If the amplifier found in part a) is used to realize an inverting opamp amplifier with a closed-loop gain of -5, estimate the resulting phase-margin (in degrees).

$$PM =$$

Analog Electronics

Equation Sheet

Constants: $k = 1.38 \times 10^{-23} \text{ JK}^{-1}$; $q = 1.602 \times 10^{-19} \text{ C}$; $V_T = kT/q \approx 26\text{mV}$ at $300 \text{ }^\circ\text{K}$;

$$\epsilon_0 = 8.854 \times 10^{-12} \text{ F/m}; k_{ox} = 3.9; C_{ox} = (k_{ox}\epsilon_0)/t_{ox}$$

NMOS: $k_n = \mu_n C_{ox} (W/L)$; $V_{in} > 0$; $v_{DS} \geq 0$; $v_{ov} = v_{GS} - V_{in}$

(triode) $v_{DS} \leq v_{ov}$ (or $v_D < v_G - V_{in}$); $i_D = k_n((v_{ov})v_{DS} - (v_{DS}^2/2))$

(active) $v_{DS} \geq v_{ov}$; $i_D = 0.5k_n v_{ov}^2 (1 + \lambda v_{DS})$; $g_m = k_n V_{ov} = 2I_D/V_{ov} = \sqrt{2k_n I_D}$; $r_s = 1/g_m$; $r_o = L/(|\lambda|I_D)$

PMOS: $k_p = \mu_p C_{ox} (W/L)$; $V_{tp} < 0$; $v_{SD} \geq 0$; $v_{ov} = v_{SG} - |V_{tp}|$

(triode) $v_{SD} \leq v_{ov}$ (or $(v_D > v_G + |V_{tp}|)$); $i_D = k_p((v_{ov})v_{SD} - (v_{SD}^2/2))$

(active) $v_{SD} \geq v_{ov}$; $i_D = 0.5k_p v_{ov}^2 (1 + |\lambda|v_{SD})$; $g_m = k_p V_{ov} = 2I_D/V_{ov} = \sqrt{2k_p I_D}$; $r_s = 1/g_m$; $r_o = L/(|\lambda|I_D)$

BJT: (active) $i_C = I_S e^{(v_{BE}/V_T)} (1 + (v_{CE}/V_A))$; $g_m = \alpha/r_e = I_C/V_T$; $r_e = V_T/I_E$; $r_\pi = \beta/g_m$; $r_o = |V_A|/I_C$

$$i_C = \beta i_B; i_E = (\beta + 1)i_B; \alpha = \beta/(\beta + 1); i_C = \alpha i_E; R_b = (\beta + 1)(r_e + R_E); R_e = (R_B + r_\pi)/(\beta + 1)$$

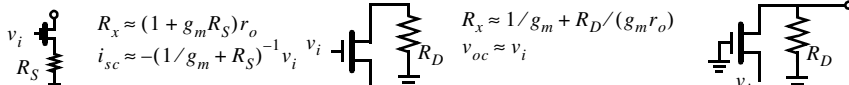
Cascode:  $R_x \approx (1 + g_m R_S) r_o$; $i_{sc} \approx -(1/g_m + R_S)^{-1} v_i$; $R_x \approx 1/g_m + R_D/(g_m r_o)$; $v_{oc} \approx v_i$; $v_o/v_i \approx g_m(r_o \parallel R_D)$ (Approx due to $g_m r_o \gg 1$)

Diff Pair: $A_d = g_m R_D$; $A_{CM} = -(R_D/(2R_{SS}))((\Delta R_D)/R_D)$; $A_{CM} = -(R_D/(2R_{SS}))((\Delta g_m)/g_m)$

$$V_{os} = \Delta V_i; V_{os} = (V_{ov}/2)((\Delta R_D)/R_D); V_{os} = (V_{ov}/2)((\Delta(W/L))/(W/L))$$

1st order: step response $y(t) = Y_\infty - (Y_\infty - Y_{0+})e^{-t/\tau}$ unity gain freq for $T(s) = \frac{A_M}{1 + s/\omega_{3dB}}$ $f_t \approx |A_M|\omega_{3dB}$ when $A_M \gg 1$

Freq: for real axis poles/zeros $T(s) = k_{dc} \frac{(1 + s/z_1)(1 + s/z_2) \dots (1 + s/z_m)}{(1 + s/\omega_1)(1 + s/\omega_2) \dots (1 + s/\omega_n)}$

OTC estimate $f_H = 1/(2\pi \sum \tau_i)$; dominant pole estimate $f_H = 1/(2\pi \tau_{max})$

Miller: $Z_1 = Z/(1 - K)$; $Z_2 = Z/(1 + K)$

Mos caps: $C_{gs} = (2/3)WLC_{ox} + WL_{ov}C_{ox}$; $C_{gd} = WL_{ov}C_{ox}$; $C_{db} = C_{db0}/(\sqrt{1 + V_{db}/V_0})$

$$f_t = g_m/(2\pi(C_{gs} + C_{gd})) \text{ assuming } C_{gd} \ll C_{gs} f_t = (3\mu V_{ov})/(4\pi L^2)$$

Feedback: $A_f = A/(1 + A\beta)$; $x_i = (1/(1 + A\beta))x_s$; $dA_f/A_f = (1/(1 + A\beta))dA/A$; $\omega_{Hf} = \omega_H(1 + A\beta)$; $\omega_{Lf} = \omega_L/(1 + A\beta)$

Loop Gain $L = -s_r/s_i$; $A_f = A_\infty(L/(1 + L)) + d/(1 + L)$; $Z_{port} = Z_{p0}((1 + L_S)/(1 + L_O))$

PM = $\angle L(j\omega_1) + 180$; GM = $-|L(j\omega_{180})|_{dB}$

Pole Splitting $\omega_{p1}' \approx 1/(g_m R_2 C_f R_1)$; $\omega_{p2}' \approx (g_m C_f)/(C_1 C_2 + C_f(C_1 + C_2))$

Pole Pair: $s^2 + (\omega_o/Q)s + \omega_o^2 = 0$; $Q \leq 0.5 \Rightarrow$ real poles; $Q > 1/\sqrt{2} \Rightarrow$ freq resp peaking

Power Amps: Class A: $\eta = (1/4)(\hat{V}_o/(IR_L))(\hat{V}_o/V_{CC})$ Class B: $\eta = (\pi/4)(\hat{V}_o/V_{CC})$; $P_{DN_max} = V_{CC}^2/(\pi^2 R_L)$

Class AB: $i_n i_p = I_Q^2$

2-stage cmos opamp: $\omega_{p1} \approx (1/(R_1 G_{m2} R_2 C_c))$; $\omega_{p2} \approx (G_{m2}/C_2)$; $\omega_z \approx (1/(C_c((1/G_{m2}) - R)))$

$$SR = I/C_c = \omega_i V_{ov1}; \text{ will not SR limit if } \omega_i \hat{V}_o < SR$$

MOS Transistor: CMOS basic parameters. Channel length = $0.18\mu m$

	V_t (V)	μC_{ox} ($\mu A/V^2$)	λ' ($\mu m/V$)	C_{ox} ($fF/\mu m^2$)	t_{ox} (nm)	L_{ov} (μm)	$\frac{C_{db0}}{W}$ ($\frac{fF}{\mu m}$)
NMOS	0.4	240	0.05	8.5	4	0.04	0.3
PMOS	-0.4	60	-0.05	8.5	4	0.04	0.3