

University of Toronto

Term Test 2

Date - Nov 20, 2015 (1:10pm to 2:00pm)

Duration: 50 min

ECE331 — Analog Electronics

Lecturer - D. Johns

ANSWER QUESTIONS ON THESE SHEETS USING BACKS IF NECESSARY

1. Equation sheet is on last page of test.
2. Unless otherwise stated, use transistor parameters on equation sheet and assume $g_m r_o \gg 1$.
3. Non-programmable calculator allowed; No other aids allowed
4. Grading indicated by []. Attempt all questions since a blank answer will certainly get 0.

Question	Mark
1	
2	
3	
4	
Total	

Last Name: SOLUTIONS

First Name: _____

Student #: _____

(max grade = 24)

[6] Question 1: Consider the circuit below where $v_{iCM} = 3V$.

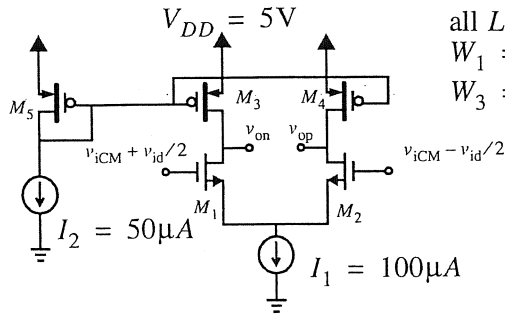

all $L = 0.2\mu m$
 $W_1 = W_2 = 5\mu m$
 $W_3 = W_4 = W_5 = 5\mu m$

$$\left(\frac{W}{L}\right)_1 = 25$$

$$\left(\frac{W}{L}\right)_3 = 25$$

$$I_{D1} = 50\mu A = I_{D3}$$

$$\mu_n C_{ox} = 240 e-6$$

$$\mu_p C_{ox} = 60 e-6$$

a) What is the max and min for v_{op} ? (assume $v_{id} = 0$)

$$V_{ov_{1,2}} = \sqrt{\frac{2I_{D1}}{\mu_n C_{ox} \left(\frac{W}{L}\right)_1}} = 0.129 V$$

$$V_{ov_{3,4}} = \sqrt{\frac{2I_{D3}}{\mu_p C_{ox} \left(\frac{W}{L}\right)_3}} = 0.258 V$$

$$V_{op_MAX} = V_{DD} - V_{ov_3} = 4.74 V$$

$$V_{op_MIN} = V_{iCM} - V_{tn} = 2.6 V$$

$$V_{tn} = 0.4 V$$

$v_{op_min} = 2.6$
$v_{op_max} = 4.74$

b) Find the gain, v_o/v_{id} . ($v_o = v_{op} - v_{on}$)

$$g_{m1} = \frac{2I_{D1}}{V_{ov_1}} = 0.775 mA/V$$

$$r_{o1} = \frac{L}{\lambda' I_{D1}} = 80 K$$

$$r_{o3} = \frac{L}{\lambda' I_{D3}} = 80 K$$

$$\frac{v_o}{v_{id}} = g_m (r_{o1} || r_{o3}) = 31$$

$v_o/v_{id} = 31 V/V$

[6] Question 2:

a) Write the transfer-function for an amplifier having ^{an} approximate gain of -100 at 100 rad/s and zeros at 1 and 10 rad/s (on the negative real axis) and poles at 5 and 1000 rad/s.

$$H(s) = \frac{k (s+1) (s+10)}{(s+5) (s+1000)}$$

$$|H(j100)| \approx -100 \approx \frac{(k) (100) (100)}{(100) (1000)} \Rightarrow k = -1000$$

$$H(s) = \frac{(-1000) (s+1) (s+10)}{(s+5) (s+1000)}$$

b) What is the dc gain of the amplifier in a)?

$$H(0) = \frac{(-1000) (1) (10)}{(5) (1000)}$$

dc gain = -2

$$H(0) = -2$$

50 MRAD/S

c) An amplifier has 2 poles at ~~50~~ and 100 Mrad/s. Using the open circuit time-constant approach, estimate the 3dB frequency for this amplifier in MHz.

$$f_{3dB} \approx \left(\frac{2\pi}{50M} + \frac{2\pi}{100M} \right)^{-1}$$

$$= 5.3 \text{ MHz}$$

$f_{3dB} = 5.3 \text{ MHz}$

[6] Question 3: Consider the amplifier circuit shown below and only the shown capacitors.

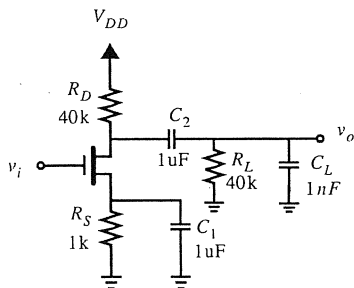

$g_m = 5\text{mA/V}$
ignore r_o

$$\frac{1}{g_m} = r_s = 200 \Omega$$

Given that a zero for this amplifier occurs at $\omega_z = 1/(R_S C_1) = 1\text{k rad/s}$ and a zero occurs dc, draw the Bode plot for this amplifier showing pole locations (in rad/s) and approximate gain values at 100 rad/s and 25k rad/s.

$$C_1 \Rightarrow \omega_{p1} = \frac{1}{C_1 (R_S \parallel \frac{1}{g_m})} = 6\text{K RAD/S}$$

$$C_2 \Rightarrow \omega_{p2} = \frac{1}{C_2 (R_D + R_L)} = 12.5\text{ RAD/S}$$

$$C_L \Rightarrow \omega_{pL} = \frac{1}{C_L (R_D \parallel R_L)} = 50\text{K RAD/S}$$

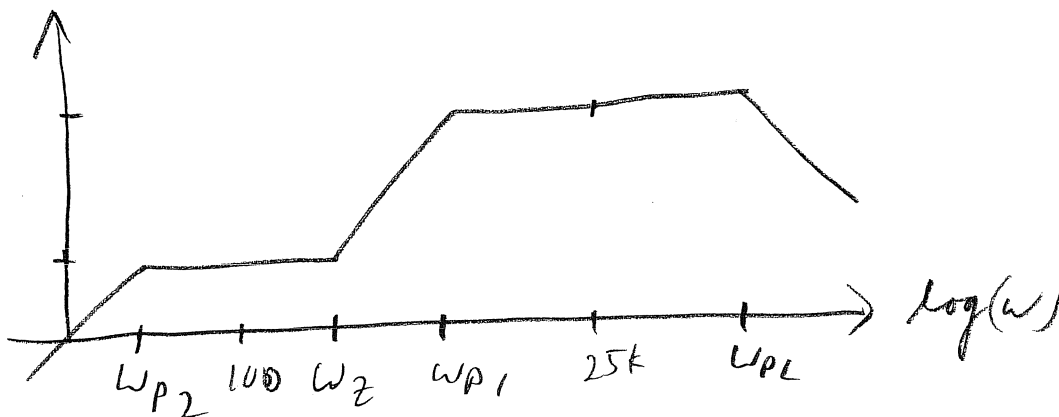

$$\left| \frac{v_o}{v_i} \right|_{100} \approx \frac{-(R_D \parallel R_L)}{r_s + R_S} = \underline{\underline{-16.7 \text{ V/V}}}$$

$$\left| \frac{v_o}{v_i} \right|_{25\text{k}} \approx \underline{\underline{-100 \text{ V/V}}}$$

[6] Question 4: Consider the differential amp shown below and only consider the capacitances shown.

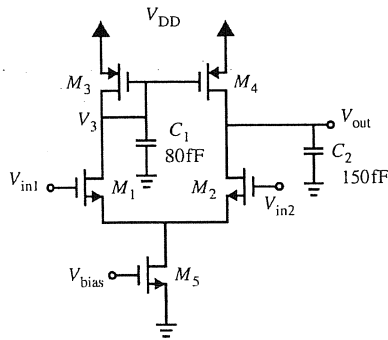

$g_{m1} = 1.5 \text{ mA/V}$	$r_{o1} = 26.7 \text{ k}\Omega$
$g_{m2} = 1.5 \text{ mA/V}$	$r_{o2} = 26.7 \text{ k}\Omega$
$g_{m3} = 1.5 \text{ mA/V}$	$r_{o3} = 26.7 \text{ k}\Omega$
$g_{m4} = 1.5 \text{ mA/V}$	$r_{o4} = 26.7 \text{ k}\Omega$
$g_{m5} = 3 \text{ mA/V}$	$r_{o5} = 13.3 \text{ k}\Omega$

$$r_{s3} = \frac{1}{g_{m3}} = 667 \Omega$$

a) Find the locations of the pole frequencies in this circuit (for the diff gain of the circuit).

$$\omega_{p1} = \frac{1}{C_1 (r_{s3} \parallel r_{o3})} \approx 18.7 \text{ GRAD/S} \Rightarrow f_{p1} = 3 \text{ GHz}$$

$$\omega_{p2} \approx \frac{1}{C_2 (r_{o2} \parallel r_{o4})} = 499 \text{ MRAD/S} \Rightarrow f_{p2} = 79 \text{ MHz}$$

b) Find the common-mode gain v_o/v_{icm} (in V/V). (Hint, v_o follows v_3 when a common-mode input signal is applied)

$$\frac{v_o}{v_{icm}} = \frac{v_3}{v_{icm}} = \frac{-r_{s3}}{2r_{o5} + r_{s1}} = \frac{-667}{26.7\text{k} + 667}$$

$$= \underline{\underline{0.024 \frac{\text{V}}{\text{V}}}}$$

Analog Electronics

Equation Sheet

Constants: $k = 1.38 \times 10^{-23} \text{ JK}^{-1}$; $q = 1.602 \times 10^{-19} \text{ C}$; $V_T = kT/q \approx 26 \text{ mV}$ at $300 \text{ }^\circ\text{K}$;

$$\epsilon_0 = 8.854 \times 10^{-12} \text{ F/m}; k_{ox} = 3.9; C_{ox} = (k_{ox}\epsilon_0)/t_{ox}$$

NMOS: $k_n = \mu_n C_{ox} (W/L)$; $V_{in} > 0$; $v_{DS} \geq 0$; $v_{ov} = v_{GS} - V_{tn}$

(triode) $v_{DS} \leq v_{ov}$ (or $v_D < v_G - V_{tn}$); $i_D = k_n(v_{ov})v_{DS} - (v_{DS}^2/2)$

(active) $v_{DS} \geq v_{ov}$; $i_D = 0.5k_n v_{ov}^2 (1 + \lambda v_{DS})$; $g_m = k_n v_{ov} = 2I_D/V_{ov} = \sqrt{2k_n I_D}$; $r_s = 1/g_m$; $r_o = L/(\lambda I_D)$

PMOS: $k_p = \mu_p C_{ox} (W/L)$; $V_{ip} < 0$; $v_{SD} \geq 0$; $v_{ov} = v_{SG} - |V_{tp}|$

(triode) $v_{SD} \leq v_{ov}$ (or $(v_D > v_G + |V_{tp}|)$); $i_D = k_p(v_{ov})v_{SD} - (v_{SD}^2/2)$

(active) $v_{SD} \geq v_{ov}$; $i_D = 0.5k_p v_{ov}^2 (1 + |\lambda| v_{SD})$; $g_m = k_p v_{ov} = 2I_D/V_{ov} = \sqrt{2k_p I_D}$; $r_s = 1/g_m$; $r_o = L/(\lambda I_D)$

BJT: (active) $i_C = I_S e^{(v_{BE}/V_T)} (1 + (v_{CE}/V_A))$; $g_m = \alpha/r_e = I_C/V_T$; $r_e = V_T/I_E$; $r_\pi = \beta/g_m$; $r_o = |V_A|/I_C$

$i_C = \beta i_B$; $i_E = (\beta + 1)i_B$; $\alpha = \beta/(\beta + 1)$; $i_C = \alpha i_E$; $R_b = (\beta + 1)(r_e + R_E)$; $R_e = (R_B + r_\pi)/(\beta + 1)$

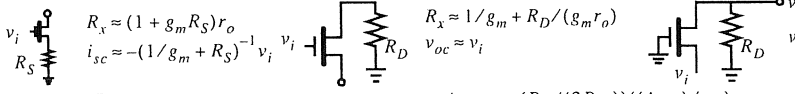
Cascode:  $R_x \approx (1 + g_m R_S) r_o$; $i_{sc} \approx -(1/g_m + R_S)^{-1} v_i$; $R_x \approx 1/g_m + R_D/(g_m r_o)$; $v_{oc} \approx v_i$; $v_o/v_i \approx g_m (r_o \parallel R_D)$ (Approx due to $g_m r_o \gg 1$)

Diff Pair: $A_d = g_m R_D$; $A_{CM} = -(R_D/(2R_{SS}))((\Delta R_D)/R_D)$; $A_{CM} = -(R_D/(2R_{SS}))((\Delta g_m)/g_m)$

$V_{os} = \Delta V_i$; $V_{os} = (V_{ov}/2)((\Delta R_D)/R_D)$; $V_{os} = (V_{ov}/2)((\Delta(W/L))/(W/L))$

1st order: step response $y(t) = Y_\infty - (Y_\infty - Y_{0+})e^{-t/\tau}$ unity gain freq for $T(s) = \frac{A_M}{1 + s/\omega_{3dB}}$ $f_T \approx |A_M|\omega_{3dB}$ when $A_M \gg 1$

Freq: for real axis poles/zeros $T(s) = k_{dc} \frac{(1 + s/z_1)(1 + s/z_2) \dots (1 + s/z_m)}{(1 + s/\omega_1)(1 + s/\omega_2) \dots (1 + s/\omega_n)}$

OTC estimate $f_H = 1/(2\pi \sum \tau_i)$; dominant pole estimate $f_H = 1/(2\pi \tau_{max})$

Miller: $Z_1 = Z/(1 - K)$; $Z_2 = Z/(1 - 1/K)$

Mos caps: $C_{gs} = (2/3)WLC_{ox} + WL_{ov}C_{ox}$; $C_{gd} = WL_{ov}C_{ox}$; $C_{db} = C_{db0}/(\sqrt{1 + V_{db}/V_D})$

$f_i = g_m/(2\pi(C_{gs} + C_{gd}))$ assuming $C_{gd} \ll C_{gs}$ $f_i = (3\mu V_{ov})/(4\pi L^2)$

Feedback: $A_f = A/(1 + A\beta)$; $x_i = (1/(1 + A\beta))x_s$; $dA_f/A_f = (1/(1 + A\beta))dA/A$; $\omega_{Hf} = \omega_H(1 + A\beta)$; $\omega_{Lf} = \omega_L/(1 + A\beta)$

Loop Gain $L \equiv -s/s_i$; $A_f = A_\infty(L/(1 + L)) + d/(1 + L)$; $Z_{port} = Z_{p0}((1 + L_S)/(1 + L_O))$

PM = $\angle L(j\omega_1) + 180$; GM = $-|L(j\omega_{180})|_{dB}$

Pole Splitting $\omega_{p1}' \approx 1/(g_m R_2 C_f R_1)$; $\omega_{p2}' \approx (g_m C_f)/(C_1 C_2 + C_f(C_1 + C_2))$

Pole Pair: $s^2 + (\omega_o/Q)s + \omega_o^2 = 0$; $Q \leq 0.5 \Rightarrow$ real poles; $Q > 1/\sqrt{2} \Rightarrow$ freq resp peaking

Power Amps: Class A: $\eta = (1/4)(\hat{V}_o/(I R_L))(\hat{V}_o/V_{CC})$ Class B: $\eta = (\pi/4)(\hat{V}_o/V_{CC})$; $P_{DN,max} = V_{CC}^2/(\pi^2 R_L)$

Class AB: $i_{n,p} = I_Q^2$

2-stage cmos opamp: $\omega_{p1} \approx (1/(R_1 G_{m2} R_2 C_c))$; $\omega_{p2} \approx (G_{m2}/C_2)$; $\omega_z \approx (1/(C_c((1/G_{m2}) - R)))$

$SR = 1/C_c = \omega_p V_{ov1}$; will not SR limit if $\omega_p \hat{V}_o < SR$

MOS Transistor: CMOS basic parameters. Channel length = $0.18 \mu\text{m}$

	V_t (V)	μC_{ox} ($\mu\text{A}/\text{V}^2$)	λ' ($\mu\text{m}/\text{V}$)	C_{ox} ($\text{fF}/\mu\text{m}^2$)	t_{ox} (nm)	L_{ov} (μm)	$\frac{C_{db0}}{W}$ ($\frac{\text{fF}}{\mu\text{m}}$)
NMOS	0.4	240	0.05	8.5	4	0.04	0.3
PMOS	-0.4	60	-0.05	8.5	4	0.04	0.3